

### RM1005ZZ-XXXXWN-9F Features:

- Single-Sided Terminals w/ Backplane Configuration
- Solder, Epoxy or Wirebondable Terminals
- Solder or Epoxy Mount Backplane
- Customer Defined Testing Available
- RoHS Compliant or SnPb Available
- Non-Magnetic Available
- Tape & Reel and Waffle Pack Available (Standard is bulk)

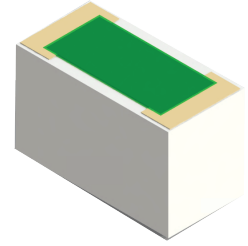

Actual Size

### RM1005ZZ-XXXXWN-9F Parameters:

Resistance Range:	0.5Ω - 1MΩ
Rated Power:*	2.5W
Construction:	Thick Film on 0.060" BeO
Operating Temperature:	-55 to +150°C

\* Rating based on ≤100°C constant baseplate temperature

### RM1005ZZ-XXXXWN-9F Dimensions:

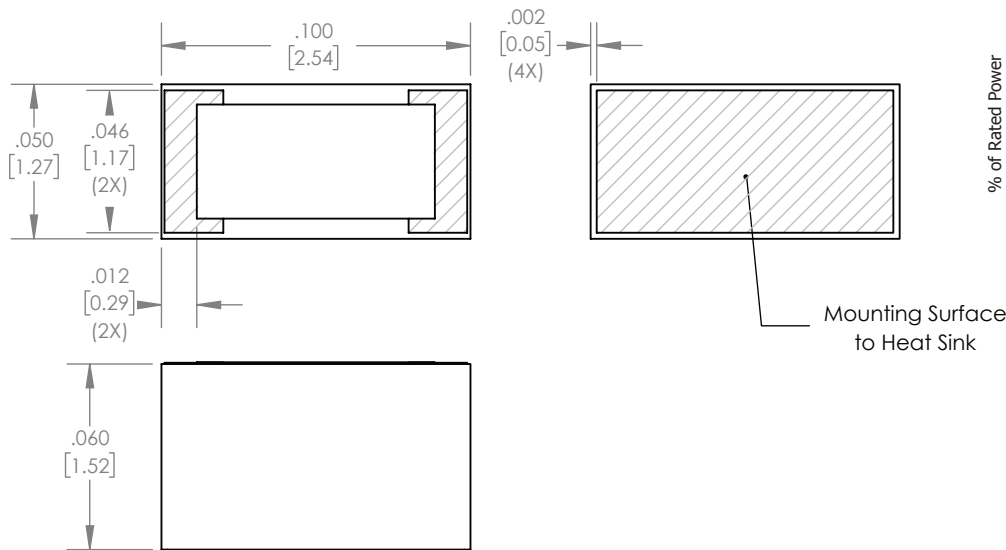

### RM1005ZZ-XXXXWN-9F Power Derating Curve

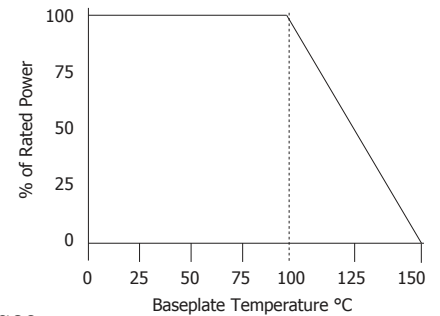

Dimensions in inches [mm]  
Tolerance is ± 0.005 [0.13]  
unless otherwise stated

### Ordering Information:

### Example Part Number: RM1005CT-50R0JN-9F

RM	1005	ZZ	-	XXXX	W	N	-	9F	UU
Prefix for Resistor w/ Single-Sided Terminals and Backplane				Value Code	Tolerance	Normal Inspection Contact factory for additional options		Substrate 9F - 0.060" BeO	Packaging Blank - Bulk WP - Waffle Pack TR - Tape & Reel
Size	1005			50R0 - 50Ω 1000 - 100Ω 1001 - 1KΩ	1002 - 10KΩ 1003 - 100KΩ 1004 - 1MΩ	F - 1% G - 2% J - 5%			

### Terminal Metallization

	RoHS	Magnetic	Solder	Epoxy	Wirebond
AS - Tin Lead over Platinum Palladium Gold	No	No	Yes	No	No
CB - Tin Lead over Nickel over Silver	No	Yes	Yes	No	No
CC - 100% Matte Tin over Copper over Silver	Yes	No	Yes	No	No
CT - 100% Matte Tin over Nickel over Silver	Yes	Yes	Yes	No	No
HA - Gold over Platinum Gold I/O Terminals w/ Platinum Palladium Gold Backplane	Yes	No	Yes (Backplane)	Yes	Yes (I/O Terminals)
JA - Gold over Platinum Palladium Gold	Yes	No	No	Yes	Yes

Barry Industries reserves the right to change part number and/or process without notification.

**RM1005ZZ-XXXXWN-9F Reliability Specifications:**

Parameter:	Test Condition:	Results:
Short Time Overload	Apply 1.1x Rated Power for 5 Seconds.	≤ 5.0% Resistance Shift
Rated Load Life	Apply 1/2 Power Under 40°C ±2°C 90 Minutes on/ 30 Minutes off. Repeat for 100 hours	≤ 5.0% Resistance Shift
Moisture Resistance	MIL-PRF-55342 para 4.8.9 95% RH, 25°C - 65°C	≤ 5.0% Resistance Shift
Resistance to Soldering Heat	MIL-STD-202 Method 210 and MIL-PRF-55342 Para 4.8.8.1	≤ 5.0% Resistance Shift
Resistance to Bonding Exposure	MIL-PRF-55342 Para 4.8.8.2	≤ 5.0% Resistance Shift
Solderability	MIL-PRF-55342 Para 4.8.12	>95% Covered
High Temperature Storage	125°C ±2°C for 500 Hours	1.) ≤ 5.0% Resistance Shift 2.) No Significant Abnormality (Visual)
Thermal Shock	-65 to +125 30 Minutes Dwell, 5 Cycles	1.) ≤ 5.0% Resistance Shift 2.) No Significant Abnormality (Visual)

Barry Industries reserves the right to change part number and/or process without notification.